



Xtreme Performance Rack Tower Series (XPRT)

User's & Installation Manual

TABLE OF CONTENTS

INTRODUCTION	7
PRODUCT DESCRIPTION	7
DETERMINING THE POWER REQUIREMENTS OF YOUR EQUIPMENT	13
HARDWARE INSTALLATION GUIDE	13
USER'S OPERATIONS.....	21
BATTERIES	26
REPLACING THE BATTERY	26
TROUBLESHOOTING	27
SPECIFICATIONS.....	28
OBTAINING SERVICE.....	31
XTREME POWER CONVERSION™ (XPC) CORPORATION LIMITED WARRANTY	32
APPENDIX A: BATTERY PACK USER GUIDE	33
APPENDIX B: SNMP CONFIGURATION GUIDE	42

INTRODUCTION

Thank you for selecting this uninterruptible power supply (UPS). It provides you with protection for connected equipment. **Please read this manual** before installing the XPRT-Series UPS models XPRT-1000, XPRT-1500, XPRT-2000 and XPRT-3000 as it provides important information that should be followed during installation and maintenance of the UPS and batteries, allowing you to correctly set up your system for the maximum safety and performance. Included is information on customer support and service, if it is required. If you experience a problem with the UPS, please refer to the Troubleshooting section in this manual to correct the problem. If the problem is not corrected, please collect information so that the Technical Support personnel can more effectively assist you.

EMC Statements - FCC Part 15

Notice: Pursuant to section 15 of the FCC rules, this product has been tested and thereby complies to the conditions of a Class B (XPRT-1000, XPRT-1500) and Class A (XPRT-2000, XPRT-3000) digital device, which have been established for offering sufficient protection against dangerous interference for installation in a residential area. Installation and use of the equipment should comply with the instructions provided in order to avoid such interference due to the amount of radio frequency energy that is radiated and generated by the equipment. In spite of this, we cannot assure that a certain amount of interference may not occur in some installations. If, by turning on and off, it can be deduced that your radio or television reception is found to be influenced by harmful interference from the equipment, it is recommended to use one of the following preventive measures.

- Place the receiving antenna in a separate location or orientation.
- Ensure a greater distance is achieved between the receiver and the equipment.
- Ensure that your equipment is connected to an outlet on a separate circuit than the receiver.
- Contact a technician experienced with radio and TV or a dealer for further assistance.

ICES-003

This Class B Interference Causing Equipment meets all requirements of the Canadian Interference Causing Equipment Regulations ICES-003. Cet appareil numérique de la classe B respecte toutes les exigences du Règlement sur le matériel brouilleur du Canada.

Declaration of Conformity Request

Units labeled with a CE mark comply with the following standards and directives:

- Harmonic Standards: EN 50091-1-1 and EN 50091-2
- EU Directives 73/23/EEC, Council Directive on equipment designed for use within certain voltage limits.
 - 96/68/EEC, Amending Directive 73/23/EEC
 - 89/336/EEC, Council Directive relating to electromagnetic compatibility
 - 92/31/EEC, Amending Directive 89/336/EEC relating to EMC
- The EC Declaration of Conformity is available upon request for products with a CE mark.

CAUTION: A shielded-type power cord is required in order to meet FCC emission limits and to prevent interference to the nearby radio or TV reception. It is essential that only the supplied power cord be used. Use only shielded cables to connect I/O devices to this equipment.

WARNING: Any changes or modifications not expressly approved by the manufacturer of this device could void the user's authority to operate the equipment.

IMPORTANT SAFETY INSTRUCTIONS:

(SAVE THESE INSTRUCTIONS)

CAUTION! (UPS having Internal Batteries): Risk of electrical shock – Hazardous live parts inside this unit are energized from the battery supply even when the input AC power is disconnected.

CAUTION! (No User serviceable Parts): Risk of electrical shock, do not remove cover. No user serviceable parts inside. Refer servicing to qualified service personnel.

CAUTION! (Non-isolated Battery supply): Risk of electric shock, battery circuit is not isolated from AC input, hazardous voltage may exist between battery terminals and ground. Test before touching.

WARNING! (Fuses): To reduce the risk of fire, replace only with the same type and size of fuse.

WARNING! Unit intended for installation in a controlled environment.

CAUTION! Do not dispose of batteries in a fire, the battery may explode.

CAUTION! Do not open or mutilate the battery, released electrolyte is harmful to the skin and eyes.

CAUTION! A battery can present a risk of electric shock and high short circuit current. The following precaution should be observed when working on batteries:

- Remove watches, rings or other metal objects.
- Use tools with insulated handles.

To reduce the risk of electric shock, disconnect the UPS from the main supply before installing a computer interface signal cable. Reconnect the power cord only after signaling interconnections have been made.

Servicing of batteries should be performed or supervised by personnel with knowledge of batteries and the required precautions. Keep unauthorized personnel away from batteries.

These UPS units are extremely heavy. Do not install the UPS in a rack or enclosure by its front two ears only. Adjustable rack rails are required for this type of installation (Part # XPRT-RR1)

The instructions contained within this safety manual are deemed important and should be closely followed at all times during installation and follow-up maintenance of the UPS and batteries.



CAUTION

The unit has a dangerous amount of voltage. If the UPS indicator is on, the unit's outlets may have a dangerous amount of voltage even when not plugged into the wall outlet because the battery may continue to supply power.

Care should be taken to undertake installation indoors, free from electrically-conductive particles which are under temperature and humidity control, in order to reduce the risk of electric shock.

It is best to disconnect the device using the power supply cord. Ensure that the equipment is placed in a position near the outlet where easily accessible.

Except for replacing the batteries, all servicing on this equipment must be carried out by qualified service personnel.

Before conducting any maintenance, repair, or shipment, first ensure that everything is turned off completely and disconnected.

For additional safety instructions, please use the Safety Manual as a reference.

Special Symbols

The following symbols used on the UPS warn you of precautions:



RISK OF ELECTRIC SHOCK - Please observe the warning that a risk of electric shock is present



CAUTION: REFER TO OPERATOR'S MANUAL - Refer to the operator's manual for additional information, such as important operating and maintenance instructions.



SAFE GROUNDING TERMINAL - Indicates primary safe ground



LOAD ON/OFF – Pressing the button turns on/off the output receptacles and the indicator light.



RJ45 RECEPTACLE – The receptacle provides network interface connections and telephone or telecommunications equipment should not be plugged into it.



Please do not discard of the UPS or the UPS batteries as the UPS may have valve-regulated lead-acid batteries. Please recycle batteries appropriately.

INTRODUCTION

The information provided in this manual covers single phase 1000-3000 VA uninterruptible power systems, their basic functions, operating procedures, options available and emergency situations. It also includes information on how to ship, store, handle, and install the equipment. Only detailed requirements of the UPS units are described herein, and installation must be carried out in accordance with this manual. Electrical installation must also carefully follow local legislation and regulations. Only qualified personnel should conduct these installations as failure to acknowledge electrical hazards could prove to be fatal.

PRODUCT DESCRIPTION

Many different kinds of sensitive electrical equipment can be protected by an Uninterruptible Power Supply (UPS) including computers, workstations, process control systems, telecommunications systems, sales terminals, other critical instrumentation, etc. The purpose of the UPS is to protect these systems from poor quality utility power, complete loss of power, or other associated problems.

Electrical interference exists in many forms, causing problems in AC power, from lightning, power company accidents and radio transmission motors, air conditioners, and vending machines. Protection of sensitive electrical equipment is vital to protect against power outages, low or high voltage conditions, slow voltage fluctuations, frequency variations, differential and common-mode noise, transients, etc.

To prevent power line problems from reaching critical systems causing damage to software, hardware, and equipment malfunctions, the UPS maintains constant voltage, isolating critical load output and cleaning the utility AC power.

Double Conversion On-Line Technology

A double conversion on-line technology UPS provides completely isolated, clean, uninterrupted single-phase power to your critical systems, while maintaining the batteries for their maximum potential. In the event that the power failure lasts longer than the UPS backup time, the UPS will shut down avoiding battery damage. When the input AC voltage returns, the UPS will automatically return online to recharge the batteries.

As shown in fig. 1 block diagram:

- An input filter reduces transients on the incoming utility.
- To maintain full battery charge, the AC input power is rectified and regulated in the rectifier feeding power to the battery converter and inverter.
- DC power is converted to AC in the inverter, passing it on to the load.

- Power is maintained from the battery during a power failure.
- The converter increases voltage appropriately for the inverter.

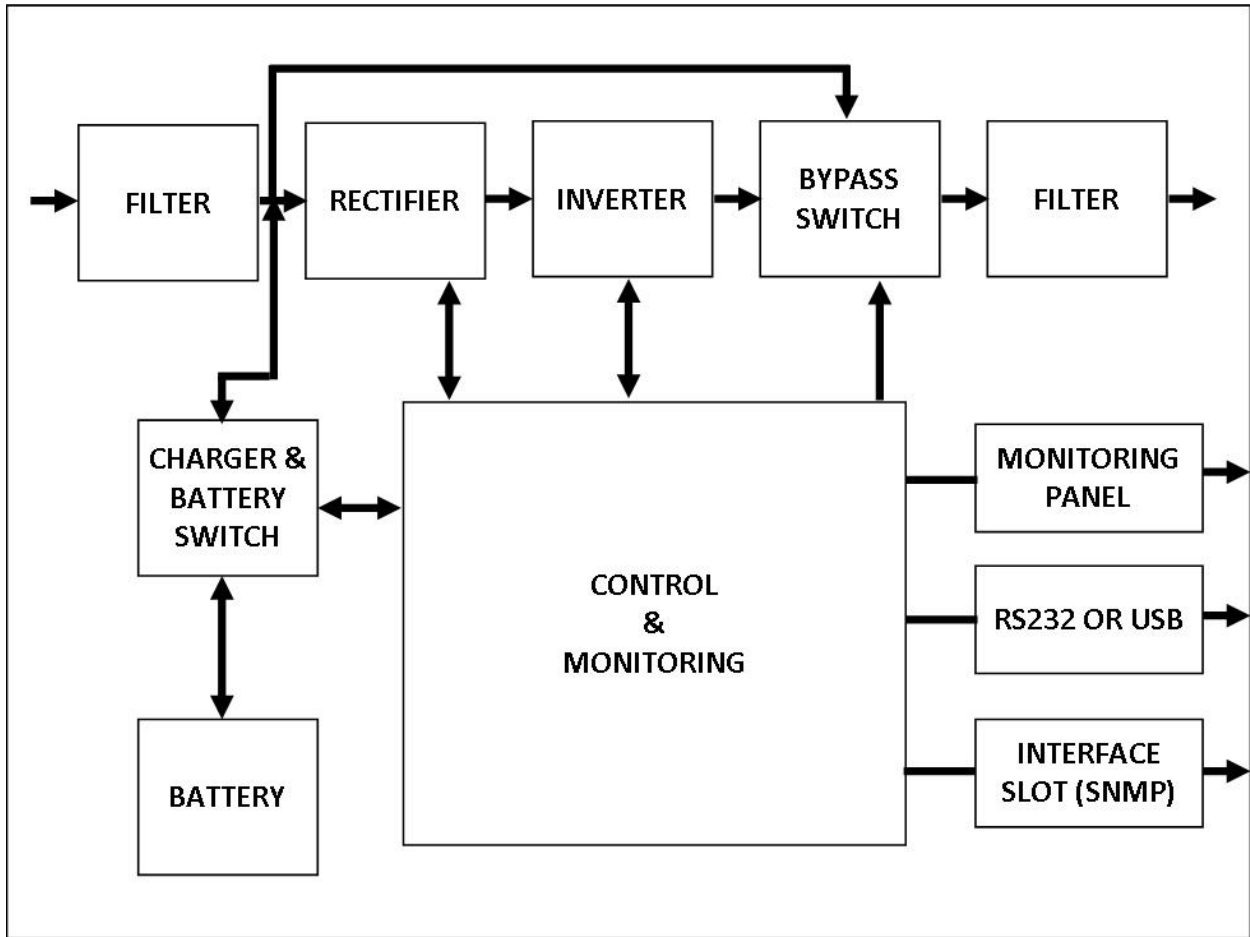

FIG 1—BLOCK DIAGRAM

Efficiency Optimizer Function

The Efficiency Optimizer Function is a new feature for the UPS, adding cost effectiveness, minimizing power loss and reducing power consumption. Alternating between bypass and on-line modes is achieved automatically and in accordance with the conditions of the utility power. On-line mode may be used during times of intermittent power, and bypass mode used when power flows smoothly, in order to obtain greatest efficiency. Irregularities can be detected in less than a second, and on-line mode reactivates immediately. Switching back to on-line mode occurs when input voltage is outside $\pm 10\%$ of nominal ($\pm 15\%$ selectable), when input frequency is outside of $\pm 3\text{Hz}$ or when no input line is available.

Although high efficiency is standard, the default operation is in on-line mode. Bypass can be activated in the LCD panel, though on-line can be run permanently if preferred.

Free Run Mode

The UPS operates in Free Run Mode when input frequency is outside of the selected input frequency range. Free Run Mode is when output frequency does not match input frequency. When starting the UPS, the frequency regulation detected is 50 or 60 Hz \pm 0.25Hz.

Diagnostic Tests

When the UPS is started, a diagnostic test is automatically executed, checking the electronics and batteries, reporting any problems on the LCD display.

An Xtreme Battery Management system always monitors the conditions of the batteries, sending any forewarnings if replacement of batteries is required. Every 30 days of normal mode operation, a battery discharge test is automatically performed, reporting any problems on the LCD display.

Except during the first 24 hours after startup while the UPS is in charging mode, diagnostic tests can be performed manually from the front panel at any time.

System Configuration

The UPS device and the internal batteries make up the system. Depending on the site and load requirements of the installation, certain additional options are available for the solution.

Planning a UPS system, the following should be taken into consideration:

- The total demand of the protected system shall dictate the output power rating (VA). Allow a margin for future expansion or calculation inaccuracies from measured power requirements.
- Backup time required will indicate the battery size needed. If the load is less than the UPS nominal power rating, then actual backup time is longer.
- The following options are available:
 - Extended Battery Packs (maximum of 2 battery packs of same model)
 - XPRT-BP1 for 1000/1500
 - XPRT-BP2 for 1000/1500
 - XPRT-BP3 for 2000/3000
 - Connectivity Options –SNMP/WEB card

See the Specification section of this manual for addition model information.



XPRT FRONT VIEW



XPRT-1000, XPRT-1500 REAR VIEW

OPTIONAL BATTERY PACK CONNECTOR



XPRT-2000/3000 REAR VIEW

EPO

Note: XPRT-2000 has (1) L5-20R + (2) 5-20R; XPRT-3000 has (1) L5-30R + (2) 5-20R

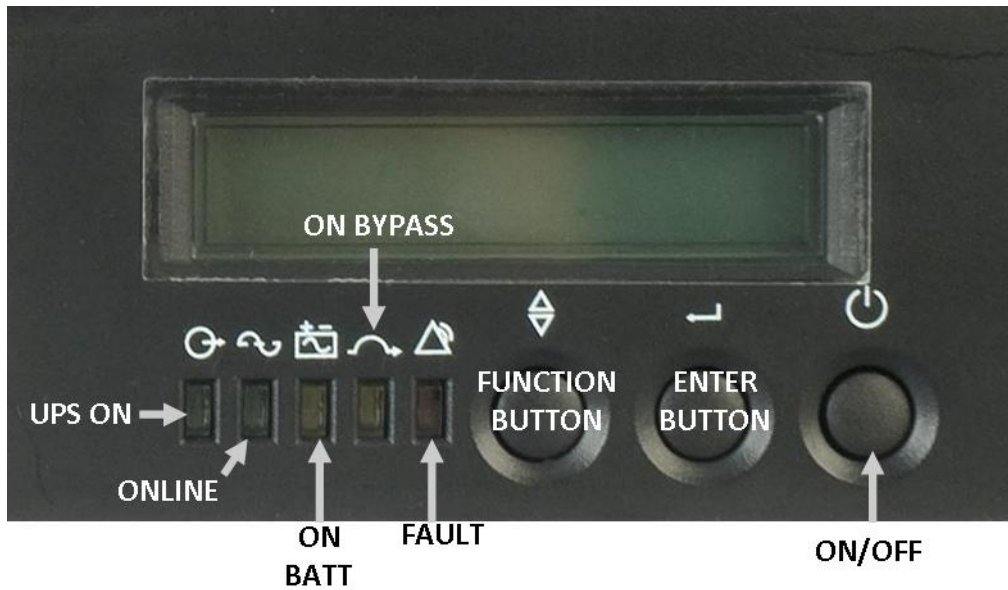

XPRT CONTROL PANEL

“UPS ON” Indicator

This LED is green when the UPS has been turned on and normal utility power is available.

“ONLINE” Indicator

This LED is green when the UPS is in normal or static bypass modes, and there is voltage at the output receptacles.

“ON BATTERY” Indicator

This LED is red when the UPS is operating in battery mode.

“ON BYPASS” Indicator

This LED is yellow when the UPS is in bypass mode.

“FAULT” Indicator

This LED is red if any internal error occurs in the UPS. An audible alarm will also be present. Press any of the buttons on the front panel to silence the alarm.

FUNCTION BUTTON

Press this button to choose which function you want on the LCD display.

ENTER BUTTON

Press this button to check the content of the UPS LDC display.

ON/OFF BUTTON

Press this button and hold for 3 seconds to turn the UPS on.

RS-232 Standard Interface

The RS-232 interface uses a 9-pin female D-sub connector. Information provided includes data about utility, load and the UPS. The interface port pins and their functions are identified in the following table:



PIN #	SIGNAL NAME	DIRECTION (RE: UPS)	FUNCTIONS
2	TxD	OUTPUT	TxD OUTPUT
3	RxD	INPUT	RxD / INVERTER OFF INPUT
5	COMMON		COMMON
6		OUTPUT	AC FAIL OUTPUT
8		OUTPUT	LOW BATTERY OUTPUT
9		OUTPUT	12VDC POWER

CAUTION: MAX RATED VALUES 12VDC

USB Port

Connecting the UPS to your computer is accomplished through the USB port on the back of your computer. USB compliant hardware and operating system will be necessary, including installation of a UPS driver. The serial port cannot be used when using the USB port. The USB cable is a standard cable included.

Emergency Power Off (EPO) Port

A customer supplied switch located remotely can be used to open the EPO connection and allows the UPS output receptacles to be switched off. Since the EPO shuts down the equipment immediately, orderly shutdown procedures are not followed by any power management software. The UPS will have to be manually restarted in order to regain power to the outlets on the UPS.

Network Transient Protector

The network transient protector located on the back panel of the UPS, has both an IN and OUT jacks, housing a single RJ-45 (10BaseT) network connector. Connect the input connector to the jack labeled IN and the output connector to the jack labeled OUT.

Storage and Transportation

Please handle the UPS and associated equipment with extreme caution since a high amount of energy is contained in the batteries. Always keep the unit in an upright position as marked on the packaging, and never drop the unit.

Please adhere to the following instructions if the UPS is not installed immediately:

- Store the equipment as is in its original packing and shipping carton.
- Do not store in temperatures outside the range of -15°C to +25°C
- Ensure that the equipment is fully protected from wet or damp areas and from moist air.

In order to maintain the batteries, the UPS should be recharged every 6 months for at least 8 hours.

If flammable substances such as gases or fumes are present, or if the room is airtight, a hazardous situation may exist in which no electrical equipment should be operated.

The instructions in this manual explain how to install the UPS safely. Not acknowledging such electrical hazards may be fatal – keep this manual for future reference.



WARNING!

It is strongly recommended that the UPS cabinet not be opened as components have very high voltage and touching those components may be fatal. Only a qualified technician or authorized agent may service the unit.

The UPS unit's output receptacles carry live voltage even when not connected to an input voltage source. The UPS has its own internal energy source.

Environment

Ensure that all environmental concerns and requirements are met according to specifications listed in this document, otherwise the safety of installation personnel cannot be guaranteed, and the unit may malfunction.

Ensure that you remember the following when locating the UPS system and battery options:

- Avoid extremes of temperature and humidity. Maximum battery life can be attained with a recommended temperature range of +15°C to +25°C.
- Provide protection for the equipment from moisture.

- Space and ventilation requirements must be met. Ensure there is 100mm behind and 50mm on the sides of the UPS for proper ventilation.
- Ensure that the front of the UPS remains clear for user operation.

INSTALLATION

Vertical Installation Steps

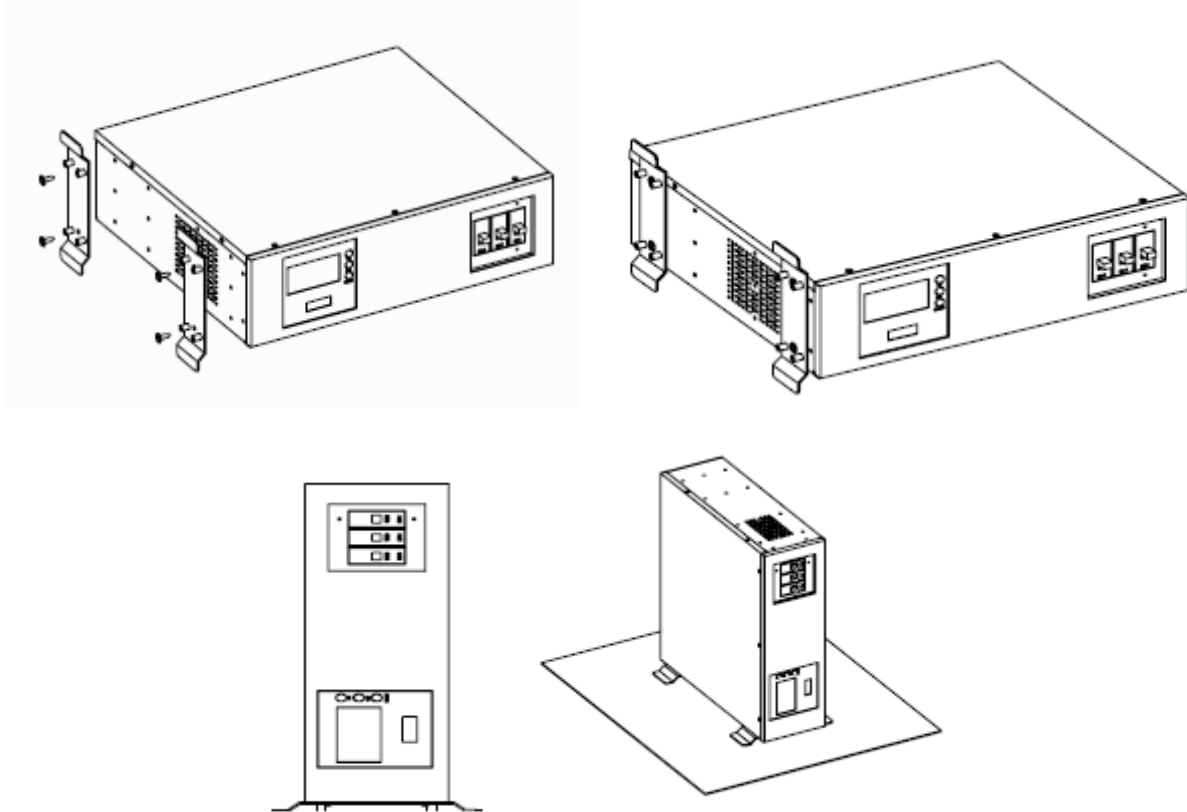

Wall-mounted Installation Steps

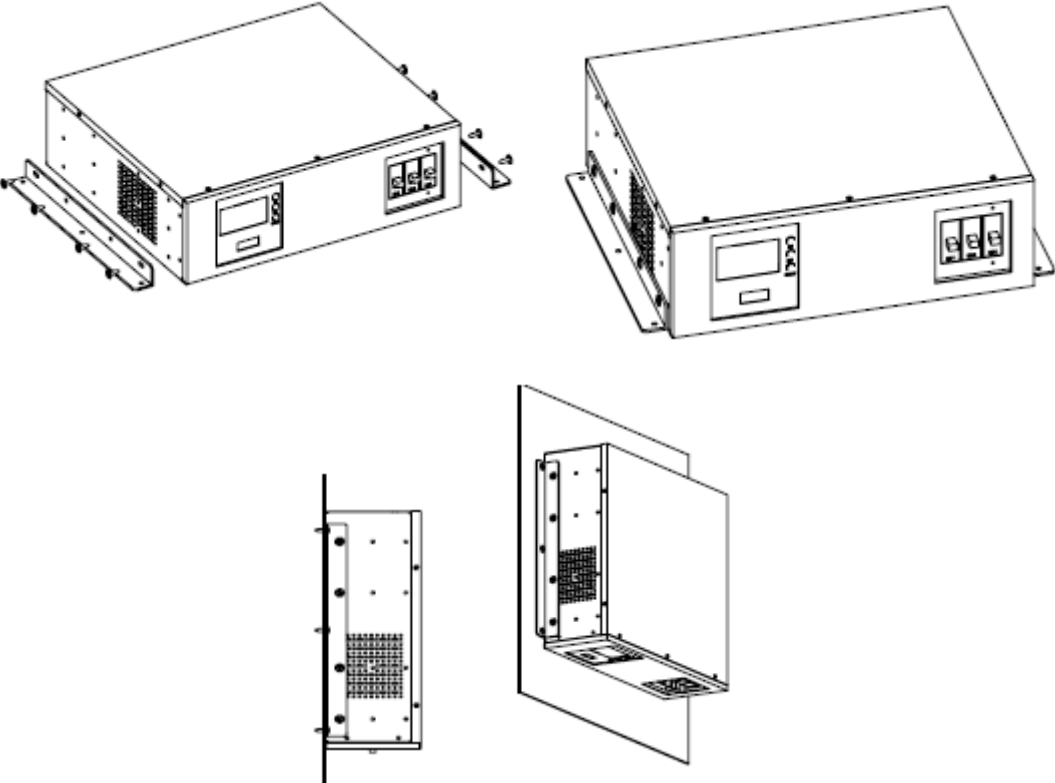

Stacked Installation Steps

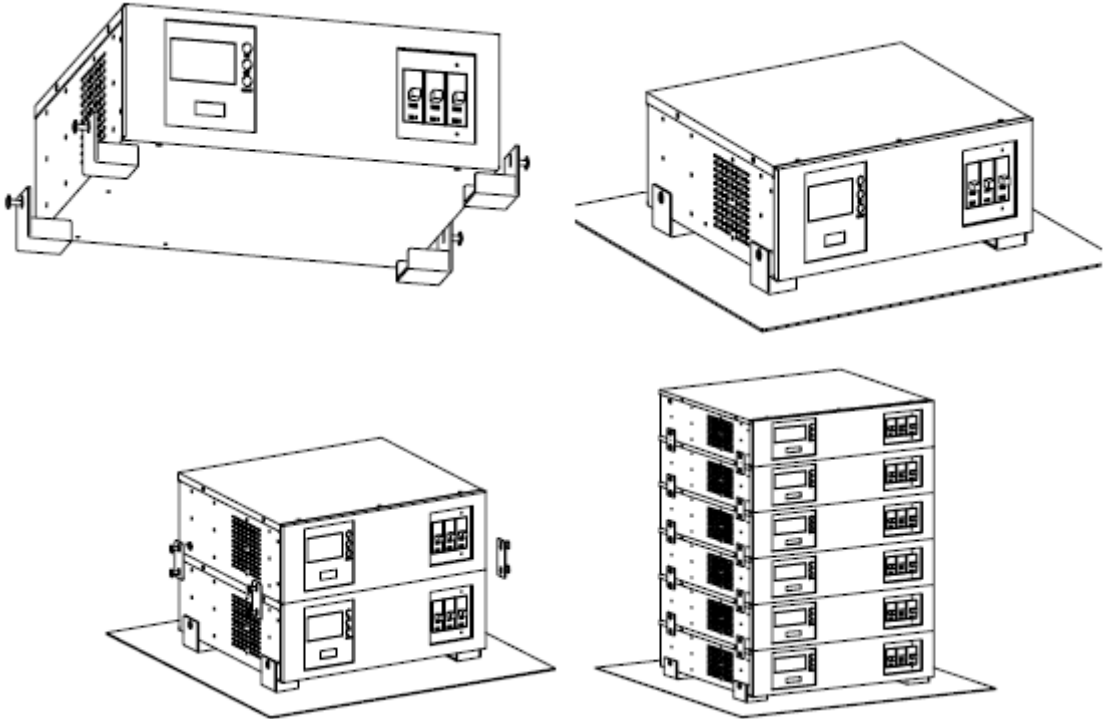

Rack-mount Installation Steps

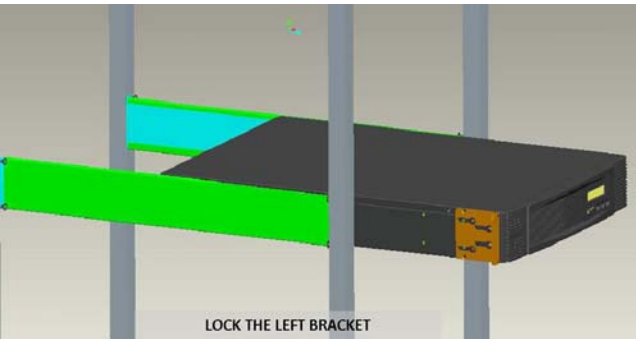
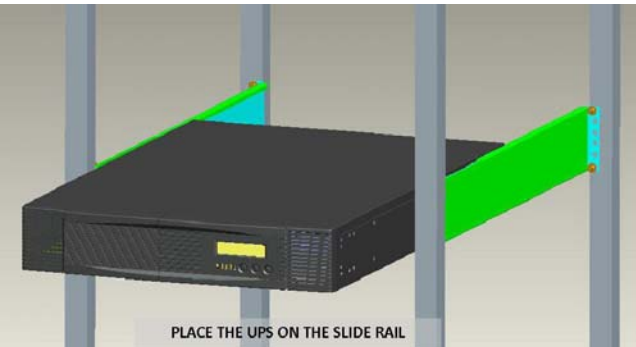
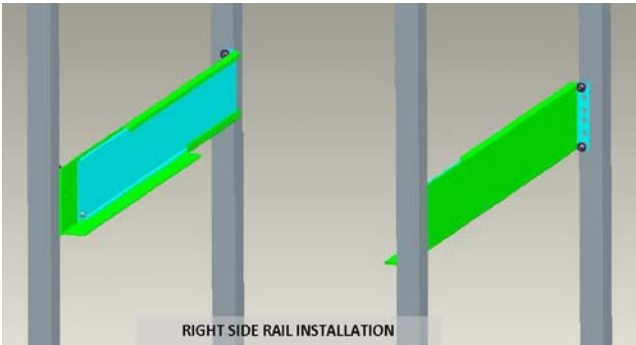
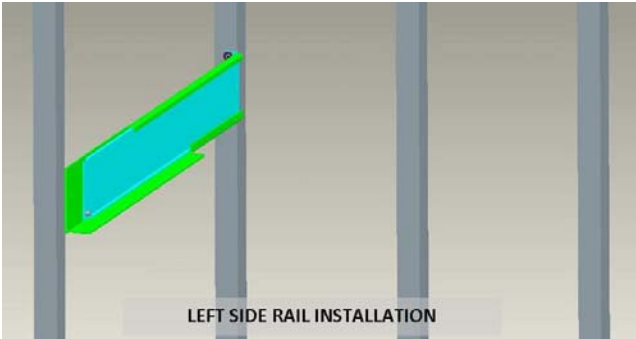

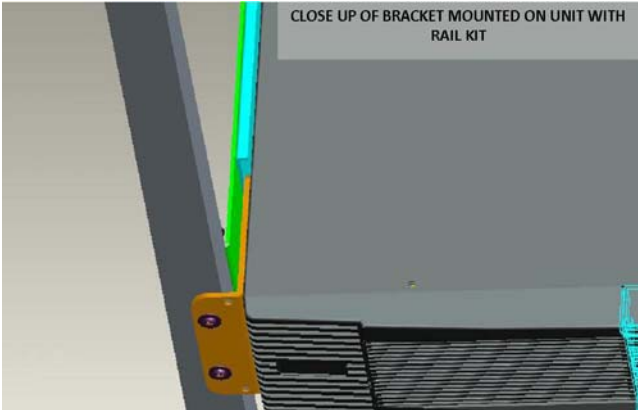
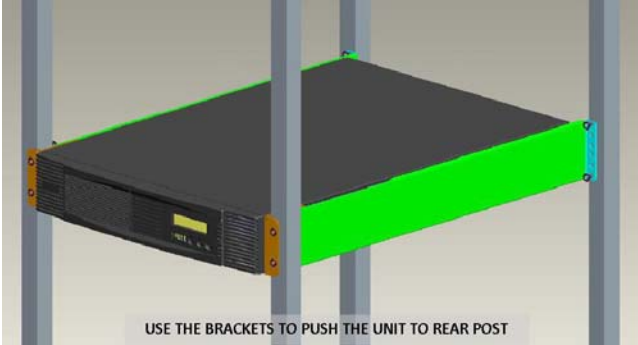
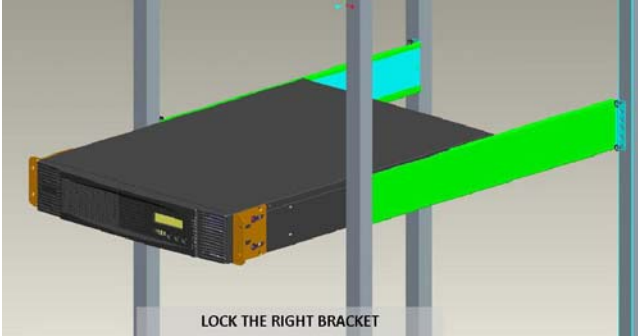

Note: Any external Battery Packs must be installed next to or under the UPS. Please refer to the Battery Pack User Guide included in the Battery Pack box for more information when installing these.

Initial Connection and Startup:

Ensure that the UPS and optional battery packs are mounted correctly, and the UPS is disconnected from input power before proceeding.

1. Connect external battery packs (option).
 - Use the cable from the External Battery Pack to connect to the UPS in the appropriate location. If a second External Battery Pack is being used, connect the cable from the second External Battery Pack to the appropriate connector in the rear of the 1st External Battery Pack. Do not close the battery breaker(s) on the battery pack(s).
 - Refer to the Battery Pack User Manual included in the Battery pack box for more details
2. Connect SNMP card (option)
 - Remove the two screws securing the SNMP cover plate on the rear of the UPS, and slide the SNMP card into the slot. Secure the card into the slot with the two screws previously removed.
3. Connect the UPS to AC power
 - Ensure the UPS line cord is connected to the appropriate grounded receptacle. The batteries will automatically charge when connected to AC input. Please note that even though you may start using the UPS immediately, maximum battery backup time may not be available until the batteries have charged for a minimum of 8 hours.
4. Start and configure the UPS
 - Start the UPS by pushing the ON/OFF BUTTON on the control panel.
 - The UPS will commence a startup self-test of internal functions including main synchronization, and inverter startup. During the startup self-test, the LCD will display: "Ready on", "Battery Mode", and "Line Mode" in that order. The UPS will remain in "Line Mode" and will be providing power to the output receptacles.
 - Program the UPS for system and site specific parameters. These are the factory function settings listed on page 23 and should only be changed if needed. For example, if optional battery packs are utilized, this is where you change the number of battery packs for runtime accuracy. This is only changed from "0" if external battery packs are being used. See "Button Operation" on page 21 to enter configuration mode via the function button and make changes to default parameters.
 - Configure the local monitoring software if desired.
 1. Insert the UPSMON CD (included with UPS packaging) into the CD ROM of the local computer.
 2. Select the appropriate installation from the Autorun menu.
 3. Follow the setup instructions. Click finish when prompted. Ensure the checkbox to start UPSMON is checked before clicking finish.
 4. The UPSMON icon will appear in the system tray of the desktop near the system clock. Double click this icon to enlarge the program window.

5. Connect the USB or RS232 cable (included in the UPS packaging) to the Computer and UPS. Communication should start momentarily. If it does not, click on Setup on UPSMON toolbar, then select Comport, and search computer ports.

CAUTION: Please verify the UPSMON shutdown settings of the UPS and Local PC by clicking on System/System configuration.

6. Click on Help in UPSMON toolbar for further software configuration.
 - Configure the optional SNMP card per Appendix "A" card instructions if option is installed.
 - Close the battery breakers on the optional battery packs if installed.
5. Connect the load to the UPS
 - Do not connect any devices that have the possibility of overloading the UPS, or drawing half-wave rectified current, such as hair dryers, vacuum cleaners, or laser printers.

Refer to the Troubleshooting section and/or Technical Support with any problems during setup.

USER'S OPERATIONS

The only operations that users are permitted to do are:

- Turning the UPS unit ON or OFF
- Operating the user interfaces
- Connecting data interface cables
- Changing the batteries

All such operations are to be performed exactly as instructed in this manual. The greatest care possible must be taken for any of these operations, and any change thereof may prove very hazardous to the operator.

Starting the UPS after initial startup

- The UPS can be started by pushing the ON/OFF BUTTON on the control panel.
- The UPS will commence a startup self-test of internal functions including main synchronization, and inverter startup. During the startup self-test, the LCD will display: "Ready on", "Battery Mode", and "Line Mode" in that order. The UPS will remain in "Line Mode" and will be providing power to the output receptacles.
- Turn all loads connected to the UPS on.

Shutting Down the UPS

- Shut down and turn off the loads connected to the UPS.

- Push the ON / OFF button on the front control panel for five seconds. The audible alarm will sound and the UPS will shut down.
- The LCD will display UPS OFF for a few seconds.
- In emergency situations, the Emergency Power Off (EPO) located on the back of the UPS should be used.

OPERATION

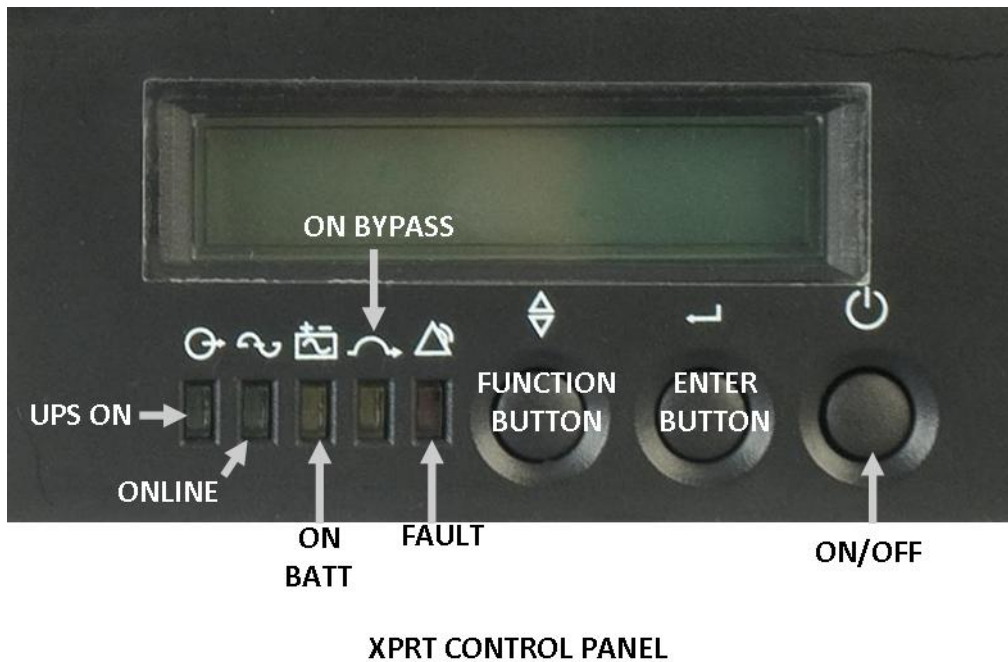

Button Operation

There are three operating buttons on the front panel.

1. ON / OFF BUTTON
 - a. Push the ON / OFF BUTTON for at least 3 seconds to turn on the UPS
 - b. Push the ON / OFF BUTTON for at least 5 seconds to turn the UPS off
2. ENTER BUTTON
 - a. Push the ENTER BUTTON for at least 2 seconds to check content of the UPS. There are fifteen functions that can be checked.
 - b. If you do not press the ENTER BUTTON within 10 seconds, the LCD will return to its original status.
3. FUNCTION BUTTON
 - a. Push the FUNCTION BUTTON for at least 2 seconds to choose the function you'd like. Each setting will be displayed by pressing once, with fourteen functions that can be checked.

- b. After choosing the function, push the ENTER BUTTON to enter the function that you want.
- c. Push the FUNCTION BUTTON to choose other functions.
- d. Push the ENTER BUTTON to enable the function selected.
- e. Push the ENTER BUTTON again to confirm and fully enable the function.
- f. If the ENTER BUTTON is not pressed within 10 seconds, the UPS will return to its original status.

UPS LCD Meter Display

Various measurements are available through the UPS LCD meter display

LCD MESSAGE	DESCRIPTION
O/P VOLT = xxx, xV	OUTPUT AC VOLTAGE
O/P FREQ = xx, x Hz	OUTPUT FREQUENCY
I/P VOLT = xxx, xV	INPUT AC VOLTAGE
I/P FREQ = xx, x Hz	INPUT FREQUENCY
BAT VOLT = xx, xV	BATTERY VOLTAGE
O/P LOAD% = xx%	LOAD % OF MAX LOAD
O/P W = xW	OUTPUT WATTS
O/P VA = xVA	OUTPUT VA
O/P CURR = xA	OUTPUT CURRENT
BACKUP TIME = xx MIN	ESTIMATED BACKUP TIME IN MINUTES
BAT CHARG = xx%	APPROXIMATE % OF BATTERY CAPACITY
TEMPERATURE = xxC	APPROXIMATE AMBIENT TEMPERATURE
BAT PACK NUM = x	QTY OF EXTERNAL BATTERY PACKS
RATING = xxxxVA	UPS RATING
CPU VERSION = xx.x	CPU VERSION

Default Factory Settings

SETTINGS	LCD DISPLAY	SELECTION	FACTORY DEFAULT
OUTPUT VOLTAGE SETTING (SELECT NOMINAL VOLTAGE)	O/P V	100/110/115/120/127 VAC	120 VAC
INPUT / BYPASS VOLTAGE (SELECT INPUT VOLTAGE RANGE WHEN BYPASS IS AVAILABLE)	I/P BYPASS	±10%	+10 / -15 %
		+10 / -15 %	
		+15 / -20 %	
INPUT / FREQUENCY (SELECT INPUT FREQUENCY RANGE WHEN UPS GOES INTO FREE RUN MODE)	I/P F	±2%	±5%
		±5%	
		±7%	
HIGH EFFICIENCY MODE SETTING (SELECT IF UPS IS TO RUN IN HIGH EFFICIENCY MODE)	HE MODE	ON / OFF	OFF
FREE RUN MODE (SELECT IF UPS CAN RUN IN FREE RUN MODE – UNSYNCHRONIZED)	FREE RUN	ON / OFF	ON
BYPASS ENABLE / DISABLE AT FREE RUN MODE (IF ENABLED THE UPS CAN GO TO BYPASS WHEN UNSYNCHRONIZED)	BYPASS DISABLED	DIABLE / ENABLE	DISABLE
FORCE MANUAL BYPASS (PERMANENTLY FORCES UPS TO BYPASS)	MANUAL BYPASS	ON / OFF	OFF
MANAGEMENT OF LOAD GROUPS (TURN TWO LOAD GROUPS ON OR OFF FROM FRONT PANEL)	OUTLET SETTING	1 ON & 2 ON 1 OFF & 2 ON 1 OFF & 2 OFF 1 ON & 2 OFF	BOTH LOAD SEGMENTS ON
BATTERY TEST (TEST TO DETERMINE IF BATTERY IS NORMAL)	BATTERY TEST		
ALARM SILENCE	SILENCE SET	ON / OFF	OFF
# OF EXTERNAL BATTERY PACKS (REQ'D TO PREDICT RUN TIME)	BAT CABINET SET	0 = ONLY UPS BATTERY 1 = ONE EXTERNAL BATTERY PACK 2 = TWO EXTERNAL BATTERY PACKS	0
SITE WIRING ALARM	SIT FAULT SET	ENABLE / DISABLE	DISABLE
SET LANGUAGE	LANGUAGE	ENGLISH, GERMAN, FRENCH, SPANISH, ITALIAN	ENGLISH
GENERATOR MODE (PLACE UNIT IN GENERATOR MODE)	GENERATOR	ON / OFF	OFF
RS232 COMMUNICATION	RS232 CONTROL	ENABLE / DISABLE	ENABLE

Manual Test of UPS

A manual UPS or manual battery test can be conducted from the UPS configuration menu.

Manual Battery Test: Scroll the parameters until MANUAL BAT TEST displays on the LDC. Press the ENTER BUTTON twice.

Note: In order for the UPS and power management software to operate normally, MANUAL BYPASS should always be set to OFF as the load will not be protected by the UPS when MANUAL BYPASS is ON. The MANUAL BYPASS is intended to operate like an external maintenance bypass switch.

Note: The UPS should be turned OFF and initialized via AC power before using the GENERATOR MODE function.

BATTERIES

The life of batteries used in these UPS products is estimated at 3-6 years depending on level of usage. Once the battery is no longer useful and must be replaced, please contact service personnel for assistance.

REPLACING THE BATTERY (QUALIFIED SERVICE PERSONNEL ONLY)

CAUTION! Read and follow the IMPORTANT SAFETY INSTRUCTIONS before servicing the battery. Service the battery under the supervision of Qualified Service Personnel knowledgeable of batteries and their precautions.

CAUTION! Use only the specified type of battery. See your dealer for replacement batteries.

CAUTION! The battery may present risk of electrical shock. Do not dispose of batteries in a fire as it may explode. Follow all local ordinances regarding proper disposal of batteries.

CAUTION! Do not open or mutilate the batteries. Released electrolyte is harmful to skin and eyes and may be toxic.

CAUTION! Although the battery voltage is only 12VDC, the battery can present a high risk of short circuit current and electrical shock. The short circuit current capability of the battery is sufficient to burn wire or tools very rapidly, producing molten metal. Observe these precautions when replacing the battery:

1. Remove all watches, rings or other metal objects.
2. Only use tools with insulated handles.
3. Do not lay tools or metal parts on top of battery or any terminals.
4. Wear protective eye wear (goggles), rubber gloves, and boots.
5. Disconnect the charging source before connecting or disconnecting the battery terminals.
6. Determine if the battery is inadvertently grounded. If inadvertently grounded, remove the source of the ground. Contact with a grounded battery can result in electrical shock! The likelihood of such shock will be reduced if such grounds are removed during installation and maintenance (applicable to a UPS and a remote battery supply not having a grounded circuit).

TROUBLESHOOTING

Displayed on LCD	Audible Alarm	Alarm Description	What You Should Do
Output Overload	Two Beeps per second	The UPS is overloaded (in Line Mode). Your equipment needs more power than the UPS can provide. The UPS operates in bypass.	Shut off the least important equipment connected to the UPS. If this solves the overload problem, the UPS will switch from bypass back to normal operation.
Battery Test	No Beeps	The UPS is doing a battery test.	No action needed. The UPS will return to normal operation when it successfully completes the battery test.
Over-Charge	Constant beep	Batteries are overcharged.	Turn off protected loads. Turn off UPS and call your local dealer
Low Battery	2 beeps every 5 seconds	The unit is operating on Battery Power and will shut down soon due to very low battery voltage. The ON Battery LED will also flash	The unit will restart Automatically when acceptable power returns.
On-Battery	Once every 5 seconds	The unit is operating on Battery Power.	Save your data and perform a controlled shutdown.
Charger Failure	Constant beep	Charger has failed.	Phone the local dealer
Over-Temperature	Constant beep	High ambient Temperature.	If the internal temperature is higher than 55C, the UPS will shutdown. Allow the UPS to cool. Make sure the unit's fans and vent holes are not blocked. Make sure the ambient surrounding temperature is not above 40 degree C. If these actions do not solve the problem, call your service representative.
Output Short	Constant beep	Output short circuit	Call the Local dealer
High output Voltage	Constant beep	High output voltage	Call the Local dealer
Low Output Voltage	Constant beep	Low output voltage	Call the Local dealer
Bus Fault	2 Beeps per second	High internal DC bus Voltage.	Turn off protected loads. Turn off UPS and call your local dealer
Site wiring Fault	1 Beep per second	Voltage detected Between Neutral and Ground	UPS mains connector polarity Wrong. Rotate the connector (Schuko). UPS installed to mains supply without ground.
Line abnormal	1 Beep per second	Wrong AC Line backed up during auto restart	

Note: The Audible Alarm can be silenced by pressing any one of the three buttons on the front of the UPS, except when a low-battery condition exists. The audible alarm can also be permanently disabled in the configuration section.

SPECIFICATIONS

	120V MODEL	XPRT-1000	XPRT-1500	XPRT-2000	XPRT-3000
INPUT	Voltage	120 VAC (80 - 144V at 100% load) 60-144V at 40% load			
	Capacity VA (W)	1000 VA (700 W)	1500 VA (1050 W)	2000 VA (1400 W)	3000 VA (2100 W)
	Frequency	50/60 Hz auto sensing			
	Power Factor	≥ 0.97			
	Topology	True on-line, Double conversion, Input PF correction, auto bypass			
OUTPUT	Voltage	120 VAC ± 2% (100/110/115/120/127 selectable via LCD)			
	Frequency	50/60 Hz auto sensing ± 0.25%			
	Load Segments	Two (2) controllable via software		n/a	
	THD (full load)	≤ 5% at full non-linear load; ≤ 3% at full linear load			
	Wave Form	Sine wave, zero transfer time			
	Load Power Factor	0.7			
	Efficiency AC/DC/AC	≥ 90%			
	Auto Restart	Yes			
	Start on Battery	Yes			
	Rated Current	8.3 A	12.5 A	16.6 A	25 A
	Overload Capacity	125% for 1 min, 150% for 10 sec			
	Crest Factor	3.0 at full load			
BATTERY	Battery Type (UPS)	(3) 12V 7.2 AH / 36V		(6) 12V 7.2AH / 72V	
	Backup Time	6 min (internal batteries) to 280 min using Battery Packs (BP)			
	Extended Battery Packs	BP1	BP2	BP3	
	Battery Type (EBP)	2 strings of (3) 12V 7.2 AH / 36V	4 strings of (3) 12V 7.2 AH / 36V	2 strings of (6) 12V 7.2 AH / 72V	
	Recharge Time	< 4 hours to 90%			

120V MODEL	XPRT-1000	XPRT-1500	XPRT-2000	XPRT-3000	
UPS PHYSICAL	Dimensions	W x D x H (inches)		W x D x H (inches)	
	Unit Dimensions (2U)	16.9" x 16.7" x 3.5"		16.9" x 25.0" x 3.5"	
	Shipping Dimensions	21.5" x 21.8" x 8.1"		21.7" x 29.6" x 8.7"	
	Unit Weight	37.6 lbs	37.6 lbs	69.5 lbs	71.5 lbs
	Shipping Weight	42.5 lbs	44.2 lbs	74.4 lbs	78.5 lbs
	Line Cord	5-15P	5-15P	5-20P	L5-30P
	Receptacles	(6) NEMA 5-15R		(1) NEMA L5-20R + (2) NEMA 5-20R	(1) NEMA L5-30R + (2) NEMA 5-20R
	Communication Interface	RS-232 and USB standard, SNMP (optional card)			
	Included in box	UPSMON CD, horizontal brackets, 5:1 brackets, manual, 6ft USB & DB9 cable			
ENVIRONMENT	Operating Temperature	0 - 40°C (32 - 104°F)			
	Audible Noise	< 40dba at one meter			
	Altitude	11500 ft (3500 m) above sea level			
	Warranty	Three years electronics / One year batteries			
APPROVALS	North America	UL cUL FCC			
INDICATORS & ALARMS	LCD Visual Display	Input/output voltage & frequency, on-line mode, back up mode, battery capacity, load level			
	Audible Alarm	Beep every 5 sec (on battery)			
	UPS Fault	Continuous beeping sound and LCD display			
BATTERY PACK PHYSICAL	Model	BP1	BP2	BP3	
	Dimensions	W x D x H (inches)	W x D x H (inches)	W x D x H (inches)	
	Unit Dimensions (2U)	16.9" x 16.7" x 3.5"	16.9" x 25.0" x 3.5"	16.9" x 25.0" x 3.5"	
	Shipping Dimensions	21.5" x 21.8" x 8.1"	21.7" x 29.6" x 8.7"	21.7" x 29.6" x 8.7"	
	Unit Weight	44.0 lbs	92.4 lbs	92.4 lbs	
	Shipping Weight	48.4 lbs	97.9 lbs	97.9 lbs	

SHIPPING LIST

1. (1) UPS
2. (1) User's and Installation Manual
3. (1) 6 ft USB-DB9 adaptor cable
4. (1) UPSMON CD (monitoring software)
5. (1) phone cord (for use with telephone/data surge protection)
6. (2) sets of 5-in-1 mounting brackets
7. (1) set of horizontal mounting brackets

OBTAINING SERVICE

If the UPS requires Service:

1. Use the TROUBLESHOOTING section in this manual to eliminate obvious causes.
2. Verify there are no circuit breakers tripped.
3. Call your dealer for assistance. If you cannot reach your dealer, or if they cannot resolve the problem, call Xtreme Power Conversion Corp Technical Support at 800.582.4524. Technical support inquiries can also be made at support@xpcc.com. Please have the following information available BEFORE calling the Technical Support Department:
 - a. Your name and address.
 - b. The serial number of the unit.
 - c. Where and when the unit was purchased.
 - d. All of the model information about your UPS.
 - e. Any information on the failure, including LED's that may or may not be illuminated.
 - f. A description of the protected equipment, including model numbers if possible.

A technician will ask you for the above information and, if possible, help solve your problem over the phone. In the event that the unit requires factory service, the technician will issue you a Return Material Authorization number (RMA).

If you are returning the UPS to Xtreme Power for service, please follow these procedures:

1. Pack the UPS in its original packaging. If the original packaging is no longer available, as the Technical Support Technician about obtaining a replacement set of packaging material. It is important to pack the UPS properly in order to avoid damage in transit. Never use Styrofoam beads for a packing material.
2. Include a letter with your name, address, daytime phone number, RMA number, a copy of your original sales receipt, and a brief description of the problem.
3. Mark the RMA number on the outside of all packages. Xtreme Power cannot accept any package without the RMA number marked on the outside of the boxes.
4. Return the UPS by insured, prepaid carrier to the address provided by the Technician.

Refer to the Warranty statements in this manual for additional details on what is covered.

XTREME POWER CONVERSION™ (XPC) CORPORATION LIMITED WARRANTY

Xtreme Power Conversion (XPC) Corporation warrants Xtreme Power Conversion equipment, when properly applied and operated within specified conditions, against faulty materials or workmanship (excluding batteries) for a period of **three years for XPRT-Series products** from the date of purchase. XPC Corporation warrants **internal batteries for a period of one year** from the date of purchase. For equipment sites within the United States and Canada, this warranty covers repair or replacement, at the sole discretion of XPC Corporation. The customer is responsible for the costs of shipping the defective product to XPC Corporation. XPC Corporation will pay for ground shipment of the repaired or replacement product. This warranty applies only to the original purchaser.

If equipment provided by XPC Corporation is found to be **Dead-on-Arrival (DOA)**, XPC Corporation will be responsible for the costs of shipping product to and returning equipment from the customer in a timely manner as agreed to with the customer, once the customer has requested and received a **Return Material Authorization (RMA)** number. DOA equipment is defined as equipment that does not properly function according to user documentation when initially received and connected in conjunction with proper procedures as shown in the user documentation or via support provided by XPC Corporation personnel or authorized agents.

This warranty shall be void if (a) the equipment is repaired or modified by anyone other than XPC Corporation or a XPC Corporation approved third party; (b) the equipment is damaged by the customer, is improperly used or stored, is subjected to an adverse operating environment, or is operated outside the limits of its electrical specifications; or (c) the equipment has been used or stored in a manner contrary to the equipment's operating manual, intended use or other written instructions. Any technical advice furnished by XPC Corporation or a XPC Corporation authorized representative before or after delivery with regard to the use or application of Xtreme Power Conversion equipment is furnished on the basis that it represents XPC Corporations best judgment under the situation and circumstances, but it is used at the recipient's sole risk.

EXCEPT AS STATED ABOVE, XPC Corporation DISCLAIMS ALL WARRANTIES, EXPRESSED OR IMPLIED, INCLUDING WARRANTIES OF MERCHANTABILITY AND FITNESS FOR A PARTICULAR PURPOSE.

EXCEPT AS STATED ABOVE, IN NO EVENT WILL XPC Corporation BE LIABLE FOR DIRECT, INDIRECT, SPECIAL, INCIDENTAL, OR CONSEQUENTIAL DAMAGES ARISING OUT OF THE USE OF Xtreme Power Conversion EQUIPMENT, including but not limited to, any costs, lost profits or revenue, loss of equipment, loss of use of equipment, loss of software, loss of data, cost of substitutes, or claims by third parties..Purchaser's sole and exclusive remedy for breach of any warranty, expressed or implied, concerning Xtreme Power Conversion equipment, and the only obligation of XPC Corporation under this warranty, shall be the repair or replacement of defective equipment, components, or parts; or, at XPC Corporations sole discretion, refund of the purchase price or substitution of an equivalent replacement product.

APPENDIX A: BATTERY PACK USER GUIDE

MODEL	LOAD		UPS	QTY OF BATTERY PACKS					
	VA	WATTS		(1) BP1	(2) BP1	(1) BP2	(2) BP2	(1) BP3	(2) BP3
XPRT-1000	500	350	15 MIN	80 MIN	150 MIN	150 MIN	280 MIN	N/A	N/A
	1000	700	6 MIN	32 MIN	65 MIN	65 MIN	140 MIN	N/A	N/A
XPRT-1500	750	525	13 MIN	40 MIN	80 MIN	80 MIN	180 MIN	N/A	N/A
	1500	1050	5 MIN	18 MIN	38 MIN	38 MIN	85 MIN	N/A	N/A
XPRT-2000	1000	700	15 MIN	N/A	N/A	N/A	N/A	80 MIN	150 MIN
	2000	1400	6 MIN	N/A	N/A	N/A	N/A	32 MIN	65 MIN
XPRT-3000	1500	1050	13 MIN	N/A	N/A	N/A	N/A	40 MIN	80 MIN
	3000	2100	5 MIN	N/A	N/A	N/A	N/A	18 MIN	40 MIN

NOTE: for estimated run times using loads different than specified above, please contact Xtreme Power Conversion at support@xpcc.com.

SAFETY WARNING AND CAUTION!

Risk of Electrical Shock: This Battery Pack contains batteries, energized parts, and hazardous electrolyte that may be harmful to personnel. Hazardous voltage may exist between battery terminals and ground. Test before touching.

This Battery Pack is designed for installation in a controlled environment. To reduce risk of fire, replace only with the same type and rating of fuse or circuit breaker.

Warning, Battery Packs are very heavy. Please be very careful when handling and installing Battery Packs. Do not install the battery pack by the two front mounting ears only. The adjustable rack rails (Model # XPRT-RR1) illustrated in this manual are required for installation in a rack.

Do not dispose of batteries in a fire. The battery may explode.

There are NO user serviceable parts inside this enclosure. Do not open or mutilate the batteries as released electrolyte is harmful to the skin and eyes. It may be toxic. Servicing of batteries should be performed or supervised by personnel with knowledge of batteries and the required precautions.

A battery can present risk of electric shock and high short circuit current. The following precautions should be observed when working with batteries:

- Remove watches, rings or other metal objects
- Use tools with insulated handles
- Wear rubber gloves and boots
- Do not lay tools or metal parts on top of batteries
- Disconnect charging source prior to connecting or disconnecting battery terminals

BATTERY PACK INSTALLATION INSTRUCTIONS

1. Install the left side rail to the posts of the rack.

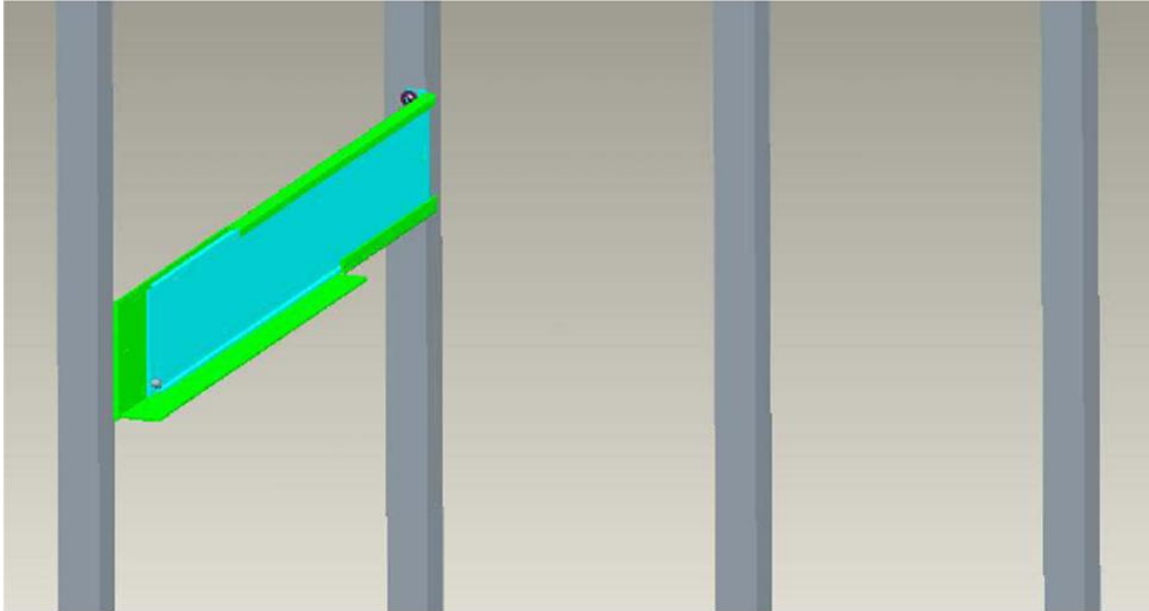

XPRT BATTERY PACK RAIL INSTALLATION STEP 1

2. Install the right side rail to the posts of the rack.

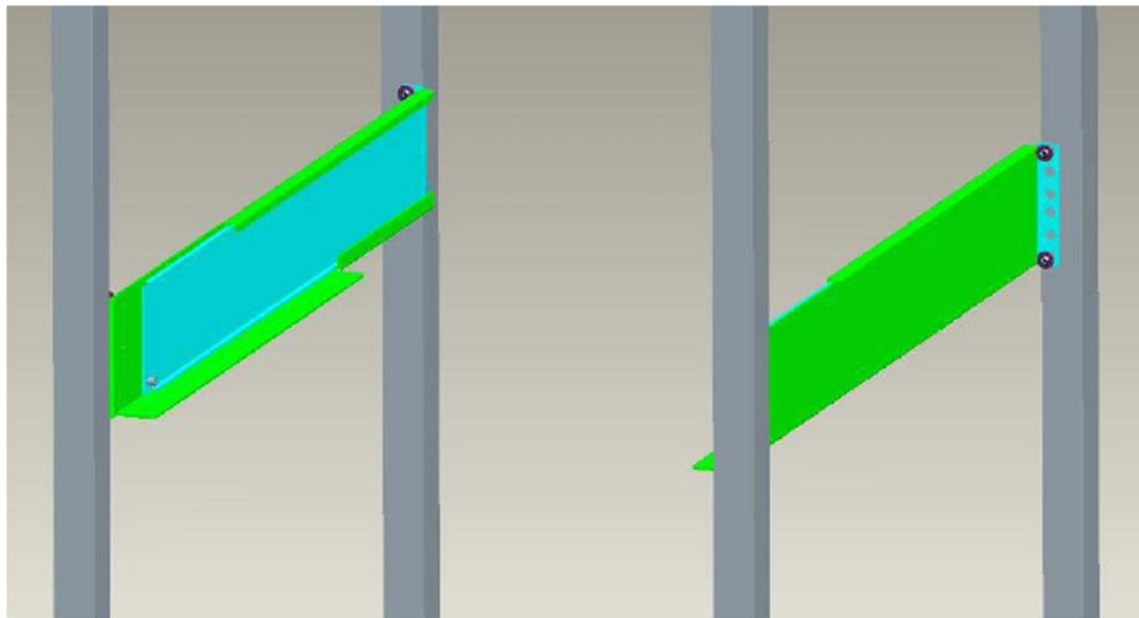

XPRT BATTERY PACK RAIL INSTALLATION STEP 2

3. Place the Battery Pack on the rails.

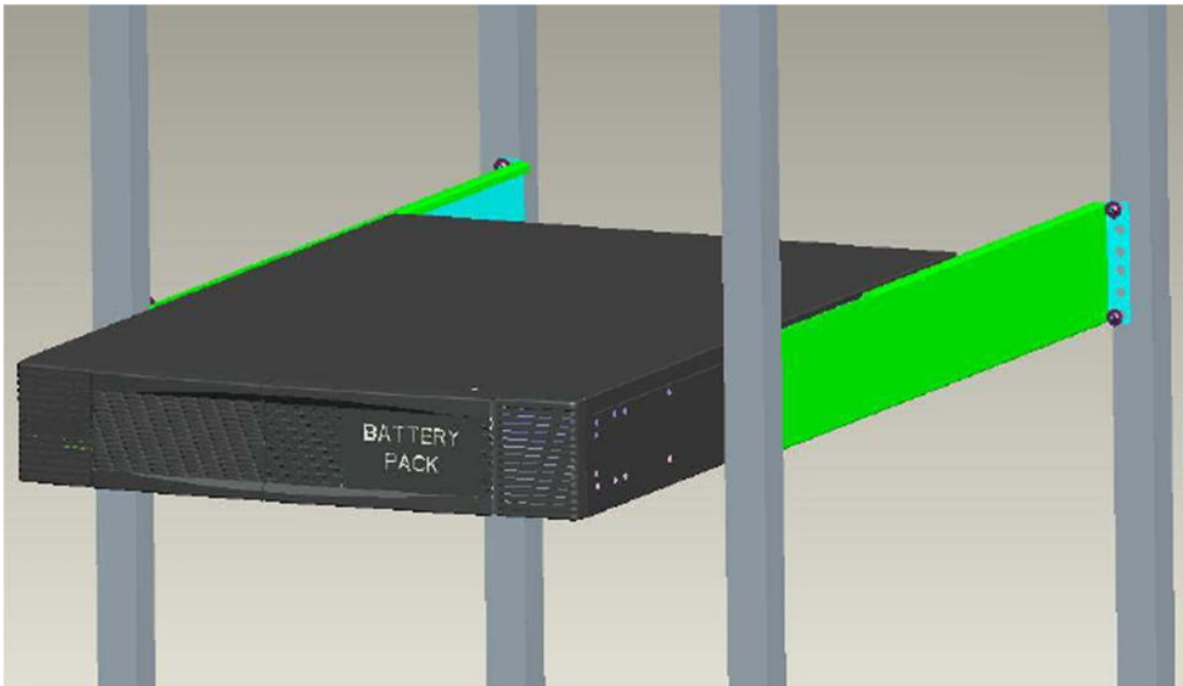

XPRT BATTERY PACK RAIL INSTALLATION STEP 3

4. Fasten the bracket to the left side of the Battery Pack.

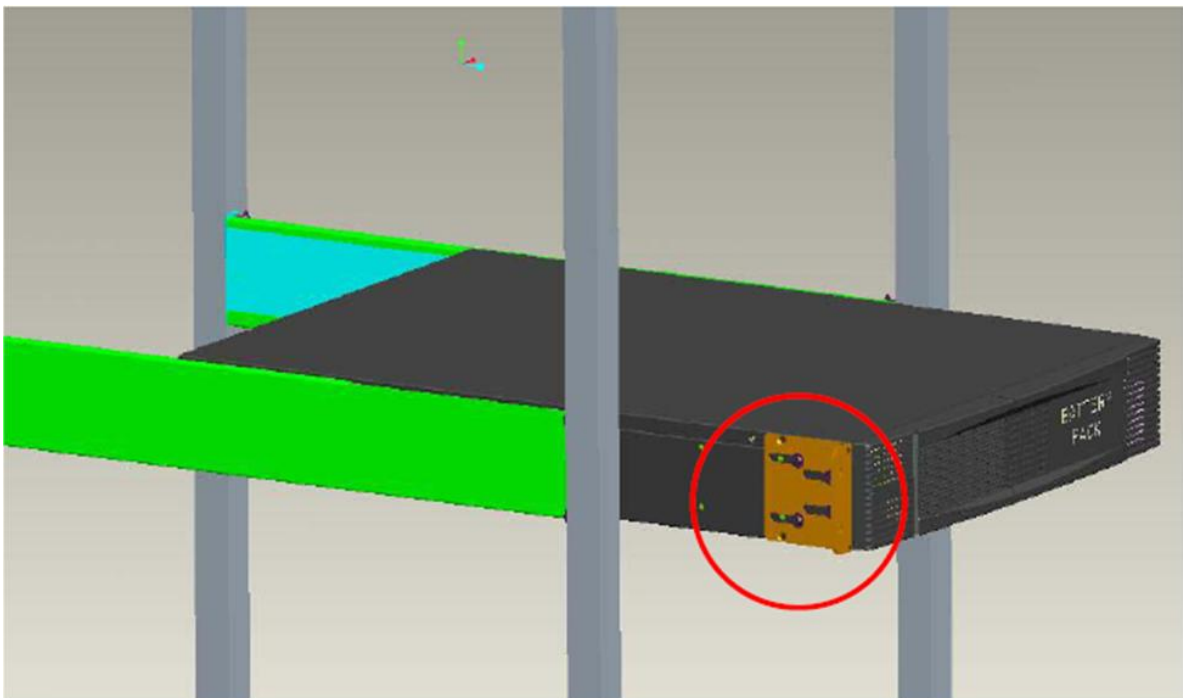

XPRT BATTERY PACK RAIL INSTALLATION STEP 4

5. Fasten the bracket to the right side of the Battery Pack.

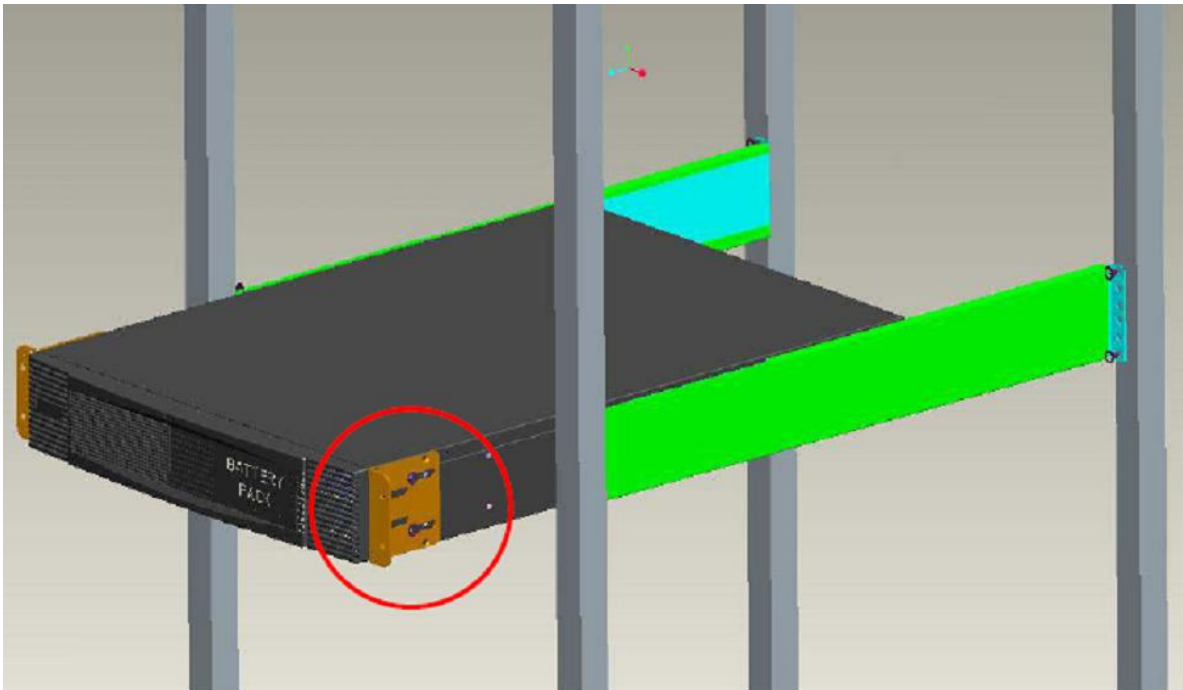

XPRT BATTERY PACK RAIL INSTALLATION STEP 5

6. Slide the Battery Pack into position, and using screws, fasten the brackets to the front posts of the rack.

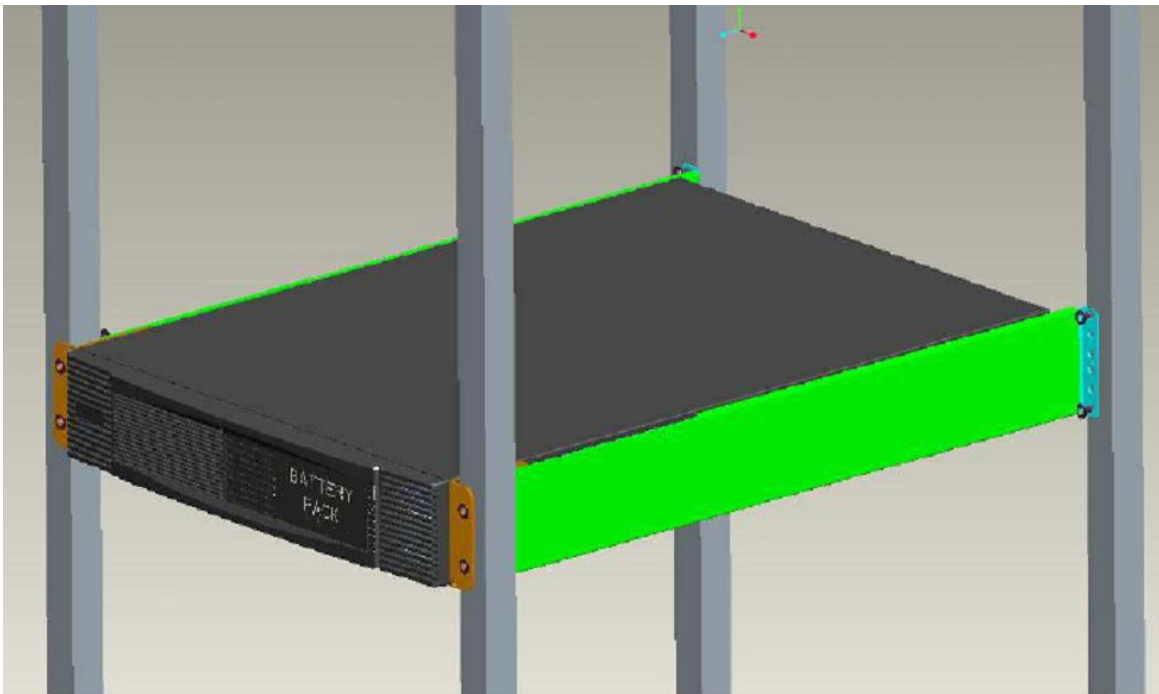

XPRT BATTERY PACK RAIL INSTALLATION STEP 6

7. Top view of the installed Battery Pack in the rack.



XPRT BATTERY PACK RAIL INSTALLATION STEP 7

8. Close-up view of the bracket on the post of the rack.

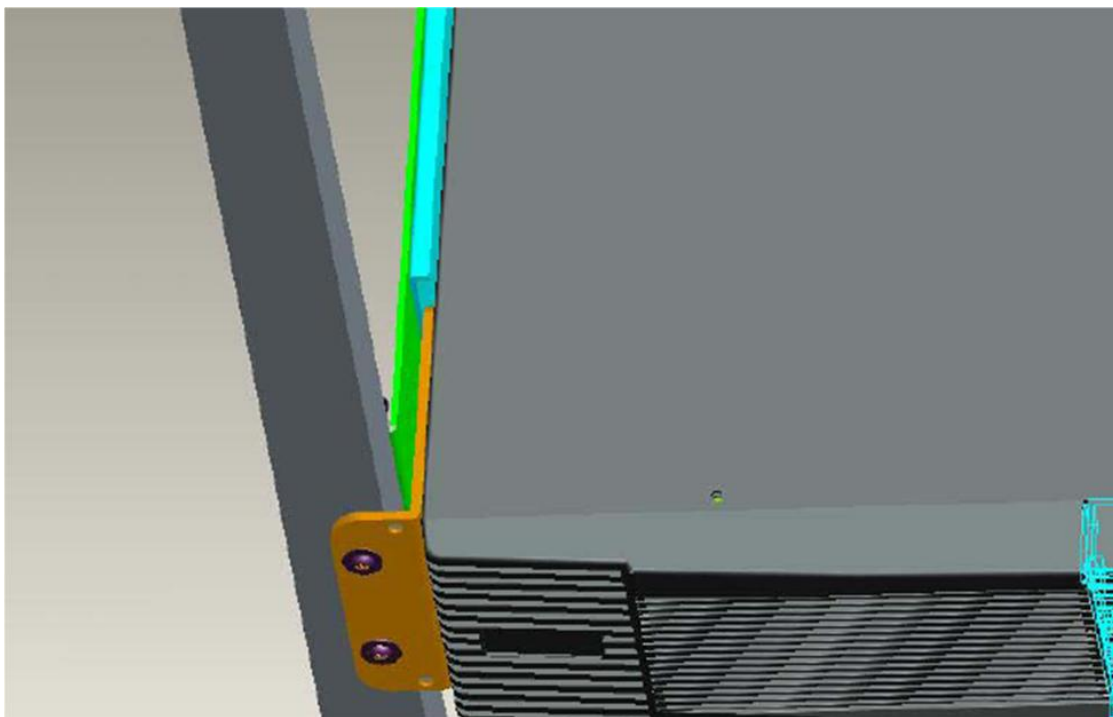

XPRT BATTERY PACK RAIL INSTALLATION STEP 8

INSTRUCTIONS FOR CONNECTING THE BATTERY PACK(S)

- Disconnect the UPS from the input utility power and remove all loads from the UPS before attempting to install a Battery Pack. Both battery circuit breakers (located on the rear of the units) must be OFF before proceeding.
- Remove the steel cover from over the battery connector on the rear of the Battery Pack and the UPS.
- Use the battery cable provided with the Battery Pack to connect the Battery Pack to the UPS.
- If more than one Battery Pack is being connected, connect the second Battery Pack to the first Battery Pack using the battery cable provided with the second Battery Pack.
- Please check and set UPS parameters to match the Battery Pack quantity installed using the front LCD panel on the UPS.

UPS

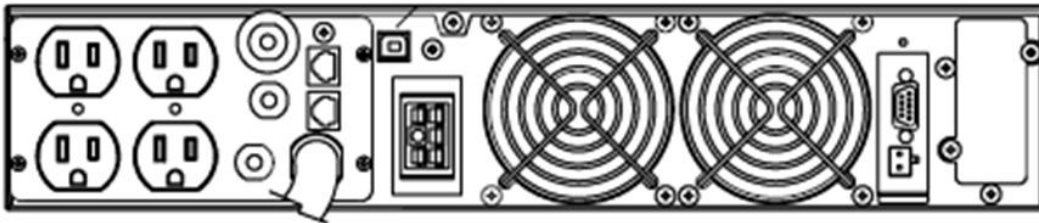

BATTERY PACK

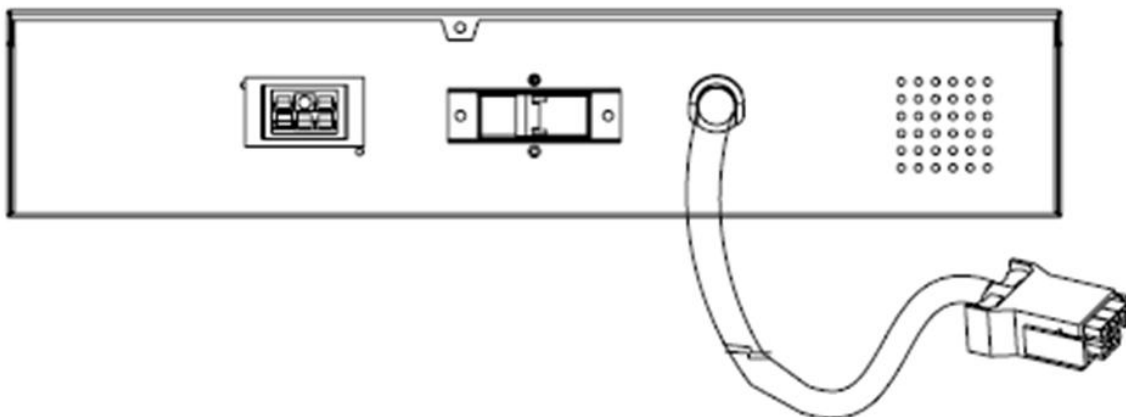

XPRT UPS TO BATTERY PACK CONNECTION FIG. 1

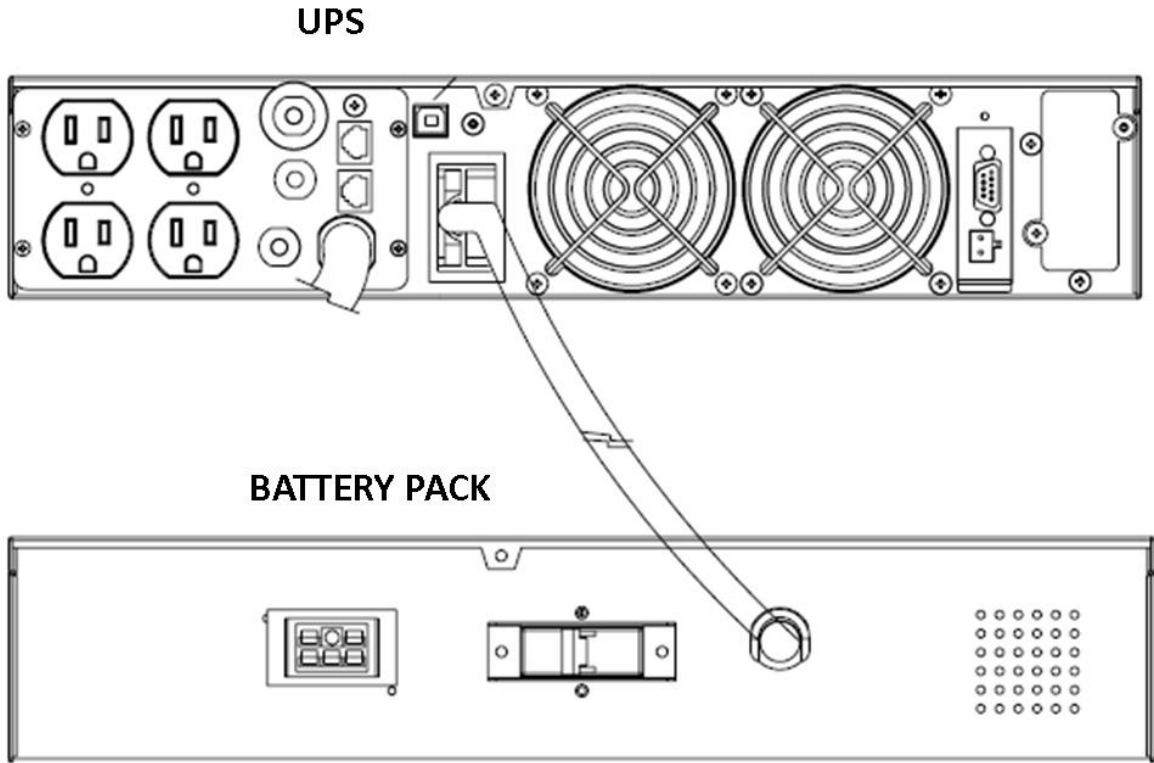

XPRT UPS TO BATTERY PACK CONNECTION FIG. 2

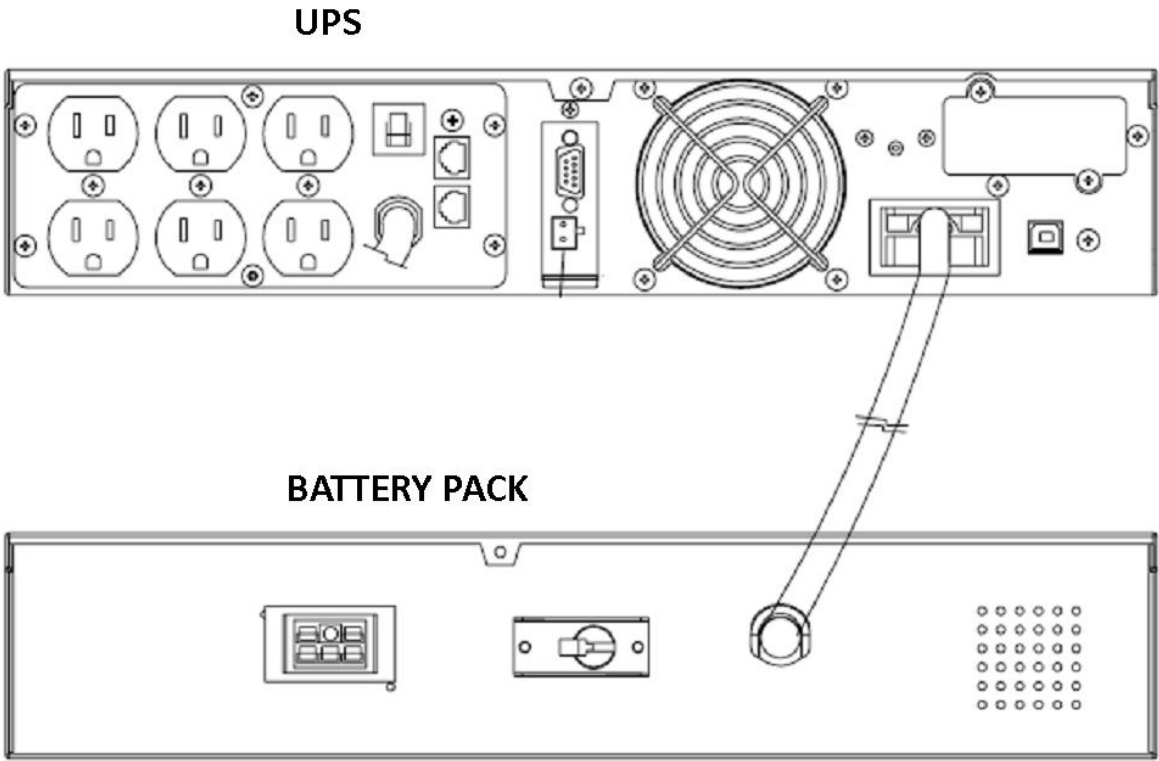

XPRT-1000/1500 UPS TO BATTERY PACK CONNECTION

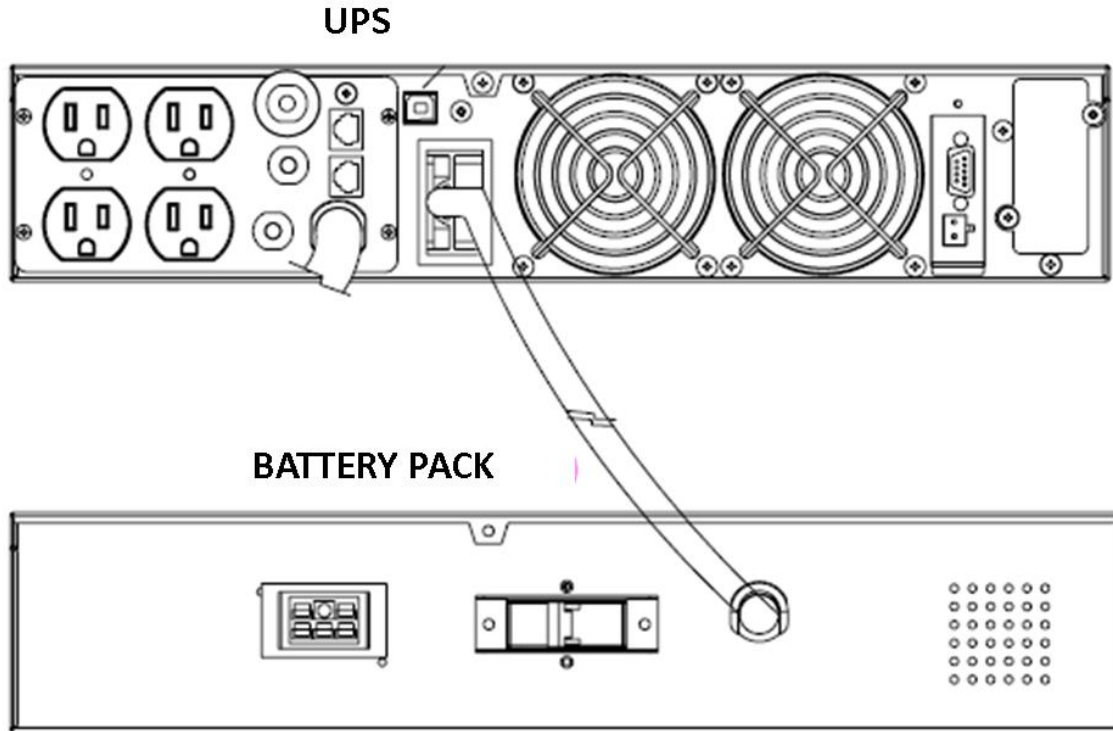

XPRT-2000/3000 UPS TO BATTERY PACK CONNECTION

APPENDIX B: SNMP CONFIGURATION GUIDE

- You must configure the Net Logic Card before it can operate properly.
- You have two methods to configure the Net Logic Card: Using telnet or terminal listed below to access the configuration screen.
- Once the SNMP card is configured and you have accessed the SNMP web page, you can view the user guide through the help section by clicking on the “?” link to further configure the SNMP card to site parameters.

CAUTION: A default setting of the SNMP card is to shutdown the UPS after 300 seconds when a utility power failure occurs. Changes to this setting can only be made through the web interface after the initial configuration with Telnet or Terminal is completed. To make changes to this setting:

1. Log into the web browser by typing the IP address in the browser's address bar.
2. Enter the username and password of *dnpower* for both fields.
3. Go to the configuration tab and select Event actions.
4. Highlight Power Failure and hit select.
5. Scroll down to Power Failure-Shutdown and uncheck “Enable”. This disables the feature
6. Leaving “Enable” checked and changing the delay time will shutdown the UPS when a power failure occurs after the specified delay time is reached.

Using Telnet

1. Make sure the Net Logic Card is plugged in the UPS properly.
2. Connect a network cable to the LAN connector on the Net Logic Card.
3. Telnet to the Net Logic Card from the PC via the path described below:

```
Start/run/telnet 192.168.1.254
```

4. Use *dnpower* for the User Name and for the Password.
5. A Configuration Screen is displayed.

Note: The default IP address of the Card is 192.168.1.254. The default login user name and password are both *dnpower*.

Using Terminal

1. Make sure the Net Logic Card is plugged in the UPS properly.
2. Connect the modem cable to the MODEM connector on the Net Logic Card.
3. Connect a null modem cable to the end of the model cable.
4. Connect the other end of the null modem cable to a serial port on your computer.

```
.NETpower <---(MODEM cable)---> <---(null modem cable)---> Computer running  
Terminal program
```

5. Make sure the serial port is not used by any program on your PC.
6. Run a terminal program, such as HyperTerminal.
7. Configure the serial port for 9600 bps, no parity, 8 data bits, 1 stop bit, and no flow control.
8. Reboot the Net Logic Card.
9. Press ESC key right after reboot. The Card/Box will detect if the user presses a ESC key for 5 seconds. If so, it will allow the user to log in; otherwise, it will try to initialize the external MODEM for other usages. So you have to press the ESC key as quickly as possible. You may keep holding the ESC without releasing it right after the system is started to make sure it will not be too late or missing.
10. Use dnpower for the User Name and for the Password.
11. A Configuration Screen is displayed.

Note: The default login user name and password are both dnpower.

Configuration Screen

When you enter into the Configuration Screen, the following menu is displayed:

```
.NETpower SNMP agent adapter Configuration
#####
<# Main Menu #>
#####
1) SNMP Agent IP Parameter
2) MIB-II System Group
3) SNMP read/write Access Control
4) SNMP Trap Receivers
5) UPS Properties
6) System Time & Time Server
7) User Account
8) E-mail Setting
9) Environmental Monitoring Module
w) Web and Telnet Service Setting
u) Upgrade firmware
r) Restore Default Configuration Data
b) Reboot SNMP agent adapter
s) Save & Reboot
Exit Without Saving

Enter Choice >>
```

SNMP Agent IP Parameter

To configure the SNMP agent IP parameters, enter a 1 at the main menu. The following screen will appear allowing you to configure IP address, Subnet Mask and Gateway.

.NETpower SNMP agent adapter Configuration

IP Parameter Setup

My IP Address: 192.168.1.254

Subnet Mask: 255.255.255.0

Router/Gateway IP Address: 192.168.1.1

- 1) Set IP Address
 - 2) Set Subnet Mask
 - 3) Set Router/Gateway IP Address
- <0> Return to previous menu

Enter Choice >>

MIB-II System Group

Enter a 2 at the main menu, the following screen will be displayed allowing you to configure some important MIB-II System Group items, including system name, contact person and system location.

.NETpower SNMP agent adapter Configuration

MIB-II System Group Setup Menu

Current values for the following MIB-II OID:

sysName: NETpower

sysContact: admin

sysLocation:

- 1) Set sysName
- 2) Set sysContact
- 3) Set sysLocation

<0> Return to previous menu

Enter Choice >>

SNMP Read/Write Access Control

Enter a 3 at the main menu, the following screen will be displayed allowing you to setup the SNMP Access Control. Enter the community number (from 1 to 4) to specify a community string, an IP address, and the access privilege.

.NETpower SNMP agent adapter Configuration

SNMP Access Control Setup Menu

Community name IP address Access

```
#1
#2
#3
#4
1) Set Access Control #1
2) Set Access Control #2
3) Set Access Control #3
4) Set Access Control #4
<0> Return to previous menu
Enter Choice >>
```

SNMP Trap Receivers

Enter a 4 at the main menu, the following screen will be displayed allowing you to setup the SNMP Trap Receivers. The Severity includes Any, Server, Warning and Informational. The Any means any event will be sent to the trap receiver. The Severe means only severe events will be sent to the trap receiver. The Warning means only warning events will be sent to the trap receiver. The Informational means only informational events will be sent to the trap receiver. The Generation item is used to enable or disable trap generation.

```
.NETpower SNMP agent adapter Configuration
SNMP Trap Receiver Setup Menu
IP address Community Severity Generation
#1
#2 192.168.1.2 public any disable
#3
#4
1) Set trap receiver #1
2) Set trap receiver #2
3) Set trap receiver #3
4) Set trap receiver #4
<0> Return to previous menu
Enter Choice >>
```

UPS Properties

Enter a 5 at the main menu; the following screen will be displayed allowing you to setup the UPS Properties, including UPS Identification Name, UPS Attached Device and Last Battery Replacement Date.

```
.NETpower SNMP agent adapter Configuration
UPS Properties Setup
UPS Identification Name: UPS
UPS Attached Device: NA
Last Battery Replacement Date: 12/31/1969
```

```

1) Set UPS Identification Name
2) Set UPS Attached Device
3) Set Last Battery Replacement Date
<0> Return to previous menu
Enter Choice >>
    
```

System Time & Time Server

Enter a 6 at the main menu, the following screen will be displayed allowing you to setup System Time. In this option, you can setup the date and time for the Net Logic Card. The SNTP Server and Time Zone settings are used for time adjustment. Specify the SNTP Server and Time Zone, and then choose 4 Adjust System Time to adjust your system time. If the values retrieved from the Internet are not what you want, you can still change the date and time manually .

```

.NETpower SNMP agent adapter Configuration
System Time & Time Server Setup
System Time: 01/07/2003 11:08:37
Time Server IP Address: 200.49.40.1
Time Zone: 0+
1) Set System Time
2) Set Time Server IP Address
3) Time Zone
4) Adjust System Time
<0> Return to previous menu
Enter Choice >>
    
```

User Account

Enter a 7 at the main menu, the following screen will be displayed allowing you to setup user accounts those who can login to the Net Logic Card.

```

.NETpower SNMP agent adapter Configuration
User Account Setup Menu
User name Password
#1 dnpower *****
#2 *****
#3 *****
#4 *****
1) Set User Account #1
2) Set User Account #2
3) Set User Account #3
4) Set User Account #4
<0> Return to previous menu
Enter Choice >>
    
```

E-mail Setting

Enter an 8 at the main menu; the following screen will be displayed allowing you to setup SMTP server. You have to setup it correctly so that the .NETpower device can sent out mails when an event occurs.

```
.NETpower SNMP agent adapter Configuration
Email Parameter Setup
SMTP Server IP Address:
1) Set SMTP IP Address
<0> Return to previous menu
Enter Choice >>
```

Environmental Monitoring Module

Enter a 9 at the main menu to setup the Environmental Monitoring Module. You have to install Environmental Monitoring Module before setup.

Web and Telnet Service Setting

Enter w at the main menu to enable/disable Web/Telnet service. Enable Web Service when you want to monitor the UPS via a web browser. Enable or disable Telnet Service to specify whether it allows users to login via telnet.

```
.NETpower SNMP agent adapter Configuration
Web and Telnet Service Setup Menu
Web Service: disable
Telnet Service: enable
1) enable Web Service
2) disable Telnet Service
<0> Return to previous menu
Enter Choice >>
```

Upgrade Firmware

Enter u at the main menu to upgrade firmware.

```
.NETpower SNMP agent adapter Configuration
Upgrade firmware
=====
1) Upgrade firmware from tftp server
2) Upgrade firmware from http server
<0> Return to previous menu
Enter Choice >>
```

When you choose 1, the following screen is displayed asking you to input the tftp server and the filename of the latest firmware. To make it work, you must have a tftp server installed and copy the firmware file to the tftp server.

```
Input the tftp server address >> 192.168.1.1
Input the file name >> dnpower.bin
```

When you choose 2, the following screen is displayed asking you to input the url pointed to the firmware file. To make it work, you must have a web server installed and copy the firmware file to the web server.

```
Input the URL (Example: http://192.168.1.1/dnpower.bin) >>
http://192.168.1.1/dnpower.bin
```

Restore Default Configuration Data

To reset the configuration data, enter r at the main menu. When the next menu is displayed, choose 1 to reset all values to their factory default settings, or choose 0 to return to the previous menu without resetting the data.

```
.NETpower SNMP agent adapter Configuration
Restore default data
=====
1) Yes, Do it
<0> Return to previous menu
Enter Choice >>
```

Reboot SNMP Agent Adapter

Enter b at the main menu to reboot the .NETpower device. All settings will not be saved. When the next menu is displayed, choose 1 to reboot the .NETpower device, or choose 0 to return to the previous menu.

```
.NETpower SNMP agent adapter Configuration
Reboot
=====
1) Yes, Do it
<0> Return to previous menu
Enter Choice >>
```

Save & Reboot

To save configuration data and reboot, enter s at the main menu. When the next menu is displayed, choose 1 to save configuration data and reboot the .NETpower device, or choose 0 to return to the previous menu.

```
.NETpower SNMP agent adapter Configuration
Save & Exit
=====
1) Yes, Do it
<0> Return to previous menu
Enter Choice >>
```

Exit Without Saving

Enter x at the main menu to exit the Configuration Screen